



Maximizing the Value of a Loop Monitoring System

Introduction

Process variability directly impacts operating efficiency, the amount of chemical and energy consumed, and product quality. As such, variability management programs offer major opportunities. Knowing the amount of variability in key processes and its impact on production and cost should mean that the key process loops are optimized and the right equipment is fixed at the right time. The ultimate result is lower production costs and higher maintenance efficiency.

An on-line tool that identifies and prioritizes control loop problems should provide an important assist in process optimization. Yet this has not been the most common outcome. After an initial period of interest, these tools too often fall into disuse. The reasons for the limited amount of success and the keys to improving the long term usefulness of these tools are the primary focus of this paper.

Background / Industry Status

High process variability increases operating costs, reduces overall efficiency and production rates. Minimizing process variability in key processes has received increasing focus over the past 15 years. There are many causes of process variability including process design issues (pump and valve sizing, pipeline design, agitator design), control strategy design, field instrumentation performance, PID tuning, and operating strategy. Achieving a low variability operation is thus a multidisciplinary activity. An on-going approach is required since process and control performance will decay over time due to deterioration in mechanical equipment, process modifications and many other factors. The process needs to be analysed periodically and improvements implemented to achieve reduced variability. Sustaining the benefits from control/variability improvements are just as critical as implementing the improvements in the first place.

Periodic Process Variability Surveys

A successful approach, pioneered by EnTech, is to conduct periodic process variability surveys, especially on high leverage process areas. High speed data acquisition equipment, hooked up to process transmitters and valve position setpoint present the clearest view of the true process variability. Time series analysis software is then used to characterize the spectral content of the variability, which helps in identifying the process source(s). Figure 1 shows an example where a high bandwidth pressure sensor was used to measure a 20 Hz pressure variation at the outlet of the primary screen which was causing severe paper quality problems. Further tests helped identifying the source of the pressure variability which was found to be a mechanical resonance problem between the screen blade frequency and the fan pump vane frequency.



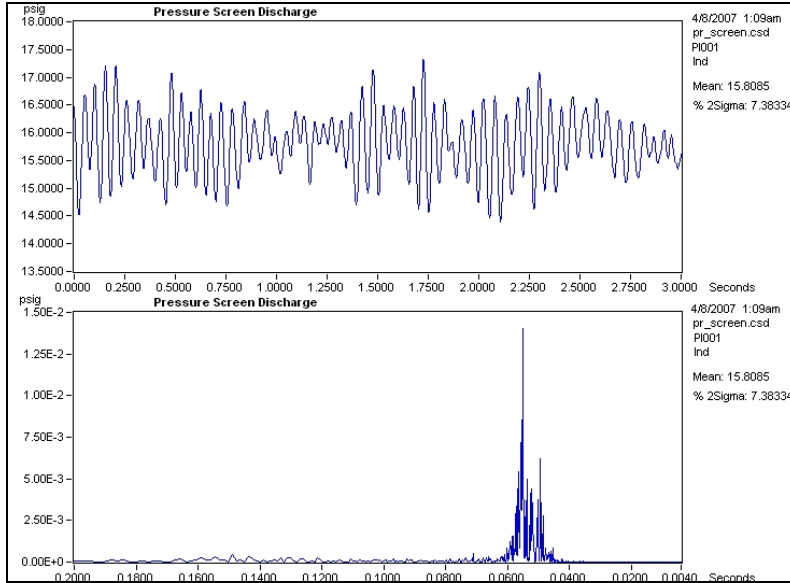

Trend plot

Power Spectrum

Figure 1 High frequency process variability

The control loop is capable of increasing process variability through control valve flaws (such as backlash and stiction), poor tuning, sensor calibration, excessive filtering and many other issues. Since process control problems have a significant impact on process variability and can easily be fixed with a limited amount of investment, these represent a central focus of the process variability surveys. Figure 2 shows how a sticky control valve can cause a process to cycle continuously. Figure 3 shows unnecessarily slow tuning on a consistency loop, compromising the ability of the loop to respond to disturbances effectively and the value of the control loop asset is not fully realized.

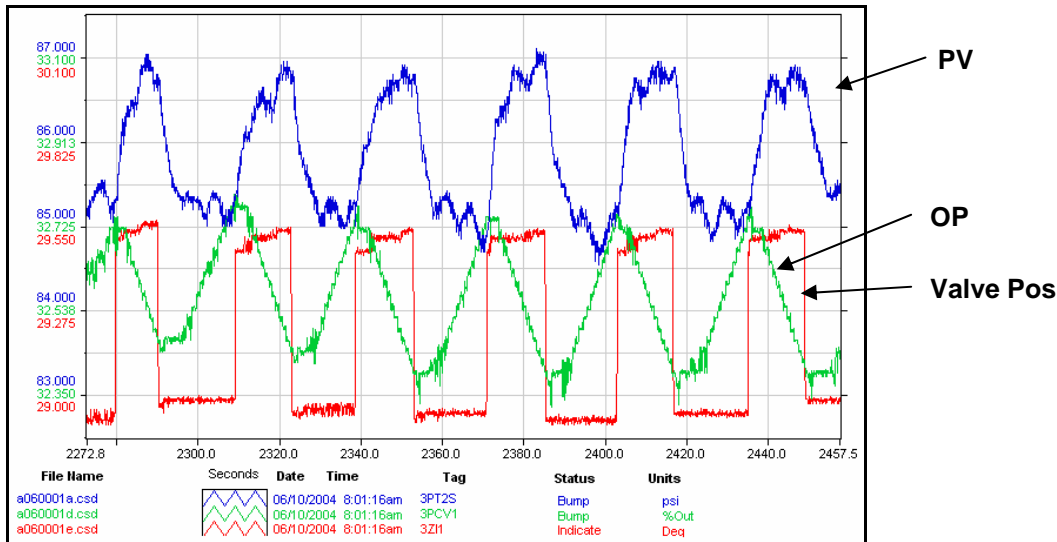

Figure 2 – Process variability caused by stiction

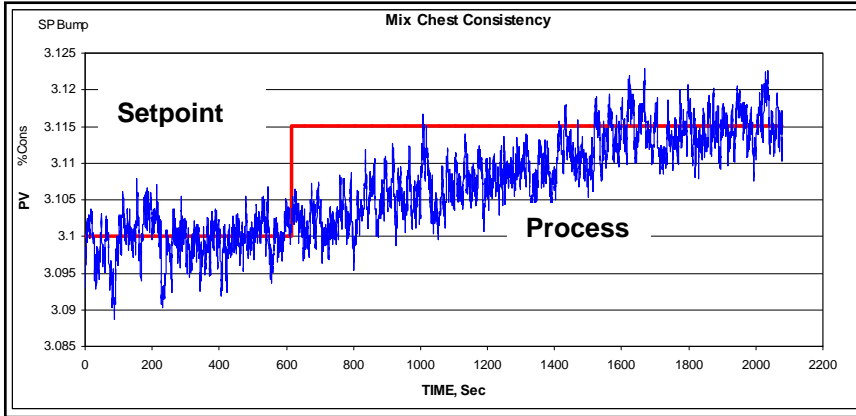

Figure 3 – Unnecessarily slow tuning on a consistency loop

The process variability will decrease with each survey as additional problems are corrected. Fixing the basement problems are the initial priority (low cost / high benefit), but may need to be followed up with control strategy modifications, process design and operating changes if further variability reduction is required. It is important to stress that although the return on investment for process control surveys is high, there will generally be an investment in time and money required *after* each survey. The recommendations for repairing/replacing control valves, repositioning sensors, modifying control strategies, modifying process equipment and operating strategies are fundamental to fully realizing the benefit of the survey. Implementing these changes requires the commitment of financial and technical resources.

What are Loop Monitoring Systems?

There are some limitations to the periodic audit approach. The ‘snapshot’ taken during the limited survey period may not provide a comprehensive view of control loop performance or process variability. For example, the pressure pulsation problem shown in Figure 1 only occurred at a specific fan pump speed (i.e. paper machine speed). Problems that develop *between* surveys or intermittently will not be recognized and corrected for an extended period, compromising long term process variability.

The next logical step in minimizing process variability is to use a Loop Monitoring System to continuously analyse the stability of the process. Loop data (PV, OP, SP, and Mode) is collected automatically through the plant control network and analysed automatically using numerical analysis tools and graphical tools that measure the loop performance in a variety of categories including valve stiction, setpoint response speed (tuning), variability, cycling frequency and others (Figure 4). The performance is rated against an acceptable performance standard in each category and an overall rating is generated. In a typical mill with several thousand control loops, this can be a powerful tool to locate problem loops. A typical weekly summary report generated by the loop monitoring system is shown in Table 1.

TABLE 1 HONEYWELL LOOPSCOUT SUMMARY REPORT

Tagname	Description	LoopType	Performance	Osc Period	CPI	COV	OPtravel	OPMean
SSFC5801	ALCOFIX FLOW	flow	saturated	1m 15s	0.71	14.39	0	-6.9
SSFC5908	TMP STK SODM HYDR FLOW	flow	saturated	3m 28s	0.01	9.18	151	36.36
P5FC5285	HB HC SCRIN REJECTS FLOW	flow	poor	35m 29s	0.87	2.13	130	23.57
SSFC5094	FLTRD W.W. TO BENT MIXER	flow	inactive	1m 30s	0	4.57	0	50
SSFC5013	SWTNR BLND CH.TO SAVEALL	flow	fair	0m 43s	0.09	6.47	445	27.21
SSFC5026	FLOW-STARCH BLEND CHEST	flow	fair	5m 4s	0.03	0.52	10	28.06
SSFC5384	SAVEALL POLYMER FLOW	flow	excellent	0m 36s	0.58	0.72	80	72.05
P5FC5666	GREEN DYE TO HDB FAN PMP	flow	acceptable	4m 12s	1	1.29	245	21.91

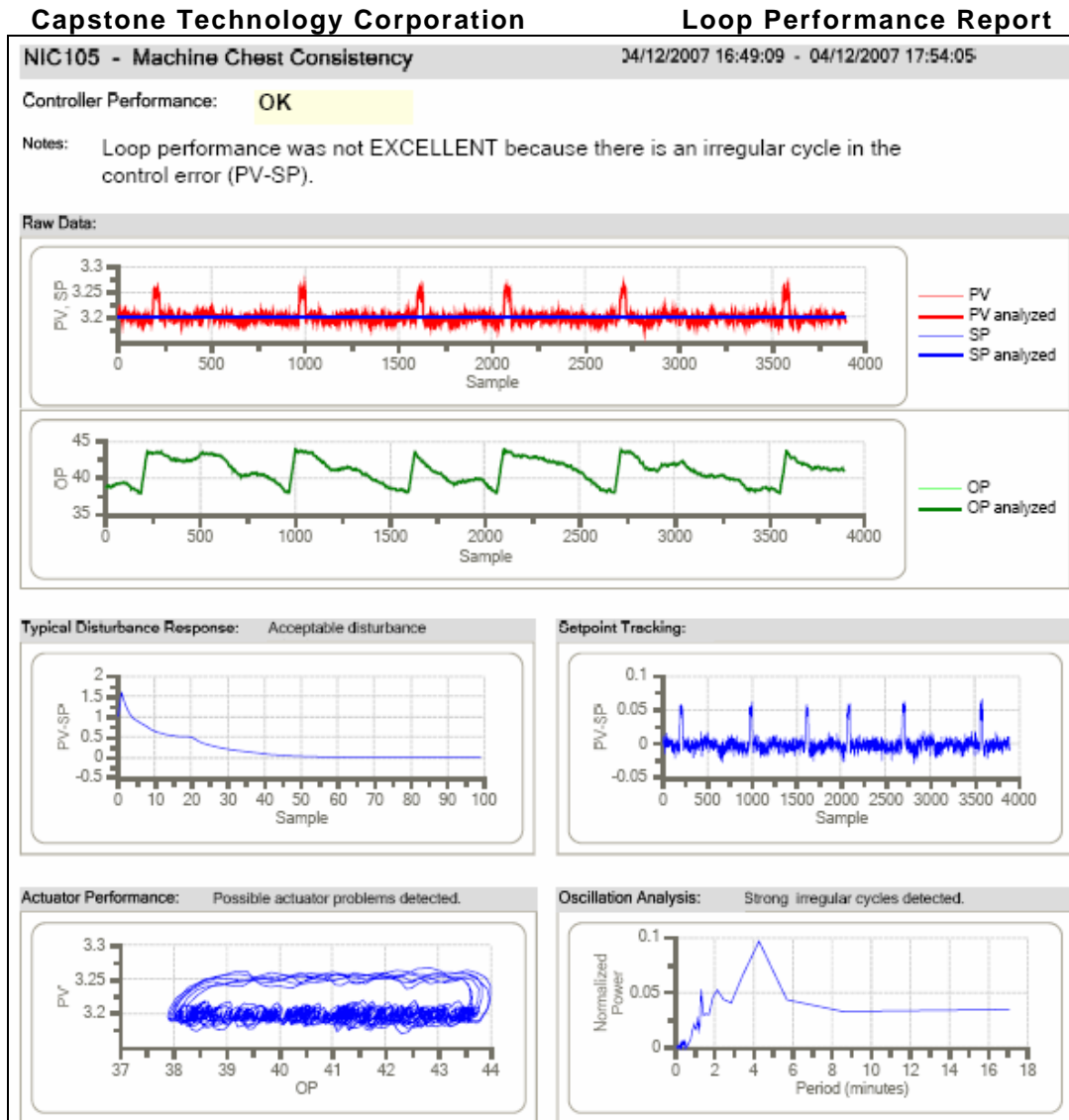

Figure 4 Loop performance report

Description of the Loop Monitoring System as process performance improvement tool

- **The idealized view**

The primary justification for purchasing a Loop Monitoring system should be to maintain process performance while minimizing the time required by humans for data analysis and process troubleshooting. However, because of the lack of skilled personnel, there is a growing need within the industry to have a Loop Monitoring system that improves process performance while requiring a minimum amount of technical resources. Although this could happen one day, Loop Monitoring systems are far from being process performance improvement tools. They should rather be viewed as an important part of a process variability reduction process.

A Loop Monitoring system that maintains performance but requires an investment in time would usually be perceived as a good investment for the mill. Unfortunately, in a quest to become the solution provider to the plants, loop monitoring systems have been sold as a silver bullet, with the idealized view that they will improve process performance while requiring a minimum of time. The marketing of Loop Monitoring systems has been so consistent in the last few years that the idealized view is now a perceived reality. Figures 5 and 6 describe the *idealized* view of loop monitoring systems.

1. The loop monitoring software has built in performance standards for a variety of loop types.
2. Loop faults are detected, diagnosed and prioritized by the loop monitoring software. A work order, with explicit instruction, is issued to the E&I mechanic who fixes the problem.
3. When the problem is fixed the monitoring software issues a report and automatically closes the work order. The monitoring tool improves maintenance efficiency, reduces long term manpower requirements (no E&I planner is required) and improves process performance.
4. The need for periodic surveys is eliminated since the process is being continually monitored and optimized. In the idealized view, the loop monitoring system is at the heart of the process optimization effort.

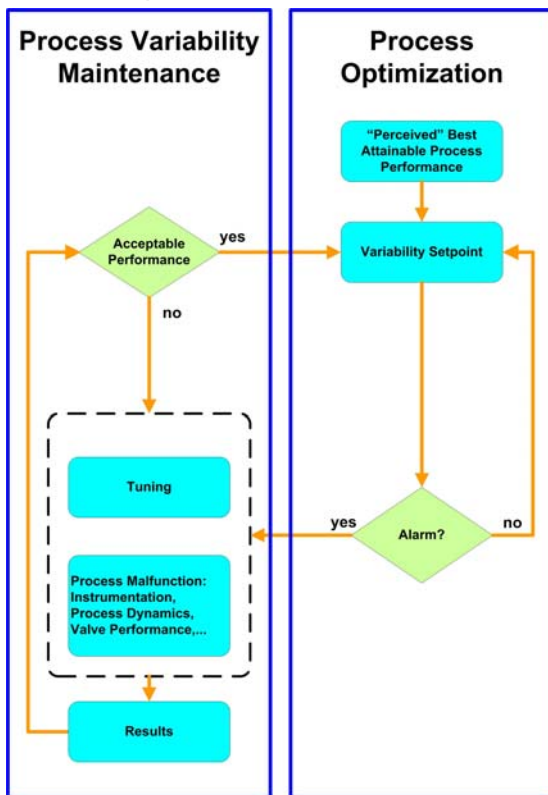

Figure 6 the loop monitoring system plays a central role in the idealized view.

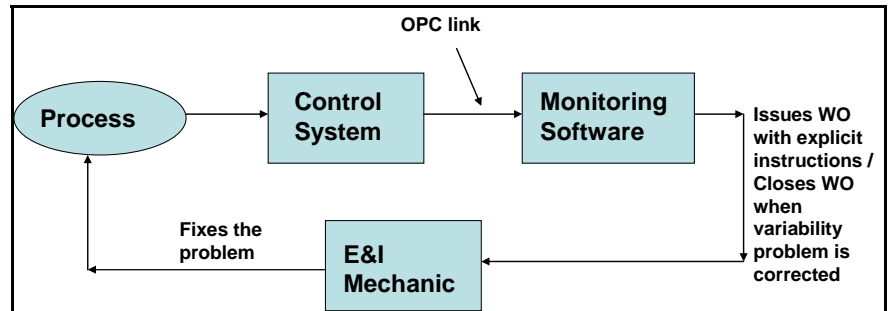

Figure 5 an idealized view of the loop optimization workflow using a loop monitoring system

Description of a Loop Monitoring System as a process performance maintenance tool (the realistic view)

Loop monitoring systems do not yet come close to the idealized view. Indeed, they should be viewed as an important tool that can assist the process optimization team at maintaining the improvements made in the process performance. With today’s technology, the process optimization team must still play a central role if the loop monitoring system is to provide value – particularly in the areas of defining the loop performance targets, and acting on the monitoring system reports (Figure 7). Defining optimum loop performance targets is an essential first step that is often overlooked. These targets should be based on comprehensive process and control surveys, where the best process performance can be realistically defined. Without good targets the loop monitoring systems system will not provide meaningful action items and could determine that the operation of a poorly performing process is acceptable. If optimum loop

performance targets are in place, the monitoring software will be able to successfully *point* at process systems that require investigation. However, the troubleshooting limitations of current loop monitoring systems will usually mean that input from an E&I person is required before action items can be developed. For example, a poorly performing control loop will spread variability to related processes and the monitoring software will have difficulty identifying the real culprit. Non-stationary variability (Figure 8) is difficult to characterize and the software will often not provide useful guidance as to the source of periodic disturbances. The monitoring system will be able to detect persistent cycling with 80% accuracy but cannot fully determine if the source is oscillatory tuning, excessive filtering or an external disturbance. The valve stiction algorithm will be accurate most of the time but the E&I mechanic must still identify whether the positioner, actuator or valve is responsible. In each case, an E&I mechanic or process engineer with real control loop troubleshooting expertise is required to complete the fix and provide value.

Moreover, the loop monitoring systems can't fully prioritize process variability issues because they lack the fundamental knowledge of process objectives or loop constraints. An individual, usually an E&I planner with a high level of process knowledge, is still required to prioritize the loop optimization tasks identified by the software. The ability of the software to identify a 'normal' operating period before collecting data is also improving but this remains a major source of false positives and user frustration.

An important issue is the inability of these systems to identify high frequency variability. If the process data is sent to the loop monitoring software through an OPC interface with a 5 second sampling rate, process cycles faster than approximately 30 seconds cannot be accurately identified and precautions are needed to prevent aliasing (Figure 9).

In summary, the primary benefit of the loop monitoring system is that it helps to target the efforts of the process optimization team. Figure 10 shows a more realistic view of the loop optimization workflow. Troubleshooting skills and high speed data acquisition tools are still a crucial component to exploiting the value of the loop monitoring system.

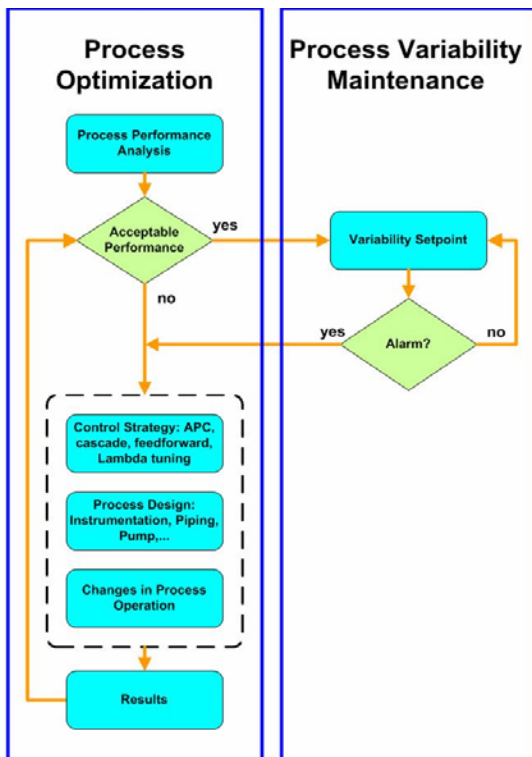

Figure 7 shows the role of the Loop Monitoring software with today's technology

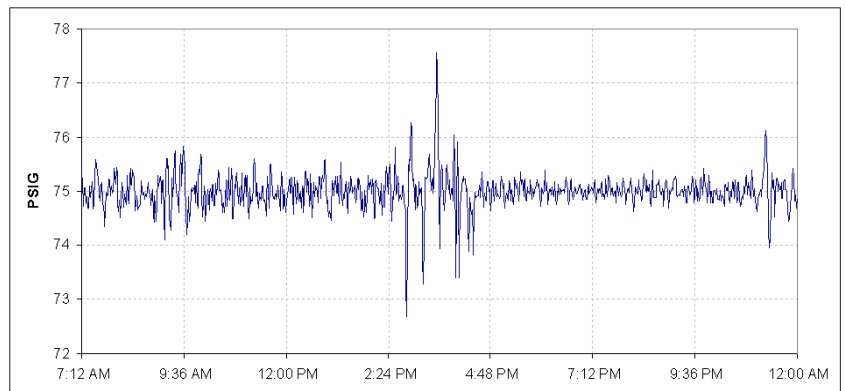

Figure 8 Non-stationary variability

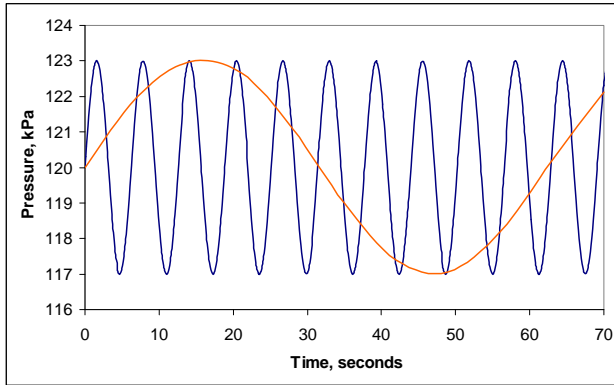

Figure 9 Aliasing due to slow sampling

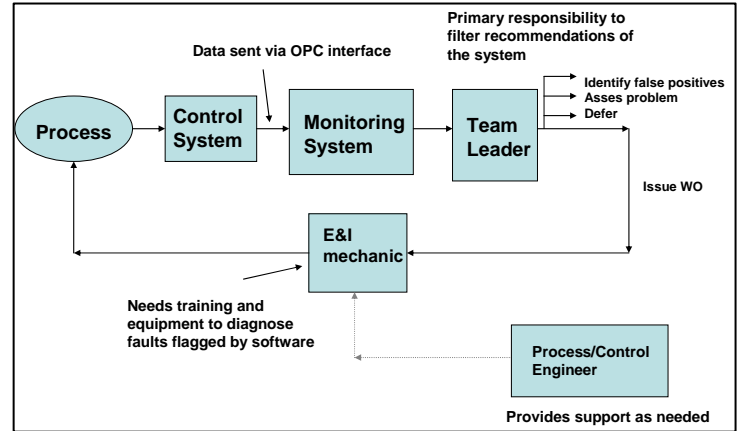

Figure 10 – shows a realistic view of the workflow using a Loop Monitoring system

Making the most of the loop monitoring capabi...,

Although these systems are clearly not a process optimization panacea, they have the potential to be an important contributor in the struggle to reduce variability, increase reliability and improve process efficiency. The users of these systems need to develop roles and procedures that take advantage of what the technology has to offer today (Table 2), and to evolve the procedures as the software becomes more powerful. Some management guidelines for maximizing the value of these systems include the following.

- Appoint a champion to take responsibility for the success of the system. This individual needs a strong background in control loop performance and time series analysis techniques.
- Ensure that the mill E&I mechanics and process engineers have the loop troubleshooting skills needed to successfully act on the monitoring system reports (Figure 11). Problems identified by the monitoring system need to be fixed before any value is added to the process.
- Review the loop monitoring reports with the E&I team on a regular basis. This will help to build an optimization awareness mentality in the E&I group and help to build diagnostic skills. The majority of E&I mechanics still think in terms of 'catastrophic failure' rather than looking for performance improvements.
- Implement the loop monitoring system *initially* on a small, high leverage process area. Audit the area before bringing the monitoring software on-line to establish a good baseline and to minimize the initial number of action items generated by the software. One recurring theme is that the production and maintenance groups are often overwhelmed by the volume of problems identified.
- Maximize the number of users of this software. The loop monitoring software can add value to the *maintenance group* by helping to transition from a reactive/preventative maintenance to condition based maintenance. The ability to identify valve tracking problems with a high degree of accuracy is a major benefit in allocating scarce resources during downtime periods – even if the software is wrong 20% of the time. The loop monitoring system can add value to the *operations group* by assisting in troubleshooting process problems. The ability of the software to identify common cycle periods can often help to narrow the field of potential sources.
- Strive to limit the number of false positive reports. Try to ensure that the process data is collected during normal operating conditions. A data set collected during a shutdown period will increase frustration level and erode confidence.
- Use the software to increase operator awareness of the process control problems and how they can affect process performance. The majority of operators have limited ability to recognize or troubleshoot process variability and control loop problems.
- Always be closing the loop on action items. These systems represent change and wins are required to establish confidence in the users. Loop monitoring systems have typically not been embraced by the E&I group, who are in firefighting or reactive mode.



TABLE 2 Loop Monitoring System Capability Overview

Good Capability	Limited Capability	No capability
Provides a quick performance overview for large numbers of loops	Providing meaningful loop performance targets	Prediction of catastrophic loop failure
Identifies deterioration in loop performance	Differentiating external disturbances from controller induced cycling	Identifying the source of cycling in interactive control loops
Identifies loops with persistent cycling and cycle periods	Identification of the source of non-linearity	Producing optimum control strategy recommendations
Detects slow setpoint or disturbance response	Identification of process dynamics	Identifying sensor calibration problems
Identifies severe non-linearities	Identification of high frequency variation (data collection limitation)	Prioritizing loops according to process impact

Conclusions

Continuous loop monitoring systems offer substantial value to the pulp and paper industry. However, the limitations of these systems need to be clearly recognized at the time of purchase. The mill needs to develop procedures so that potential benefits of these systems can be exploited. Optimum loop performance targets should be developed after a comprehensive process and control survey has been conducted. The optimization team members need to be trained in loop optimization fundamentals before the loop monitoring system starts to generate action items. The maintenance group can use the loop monitoring system to transition from preventative maintenance to condition based maintenance. The operations group can use the loop monitoring system to assist in troubleshooting process problems and improve process efficiency.

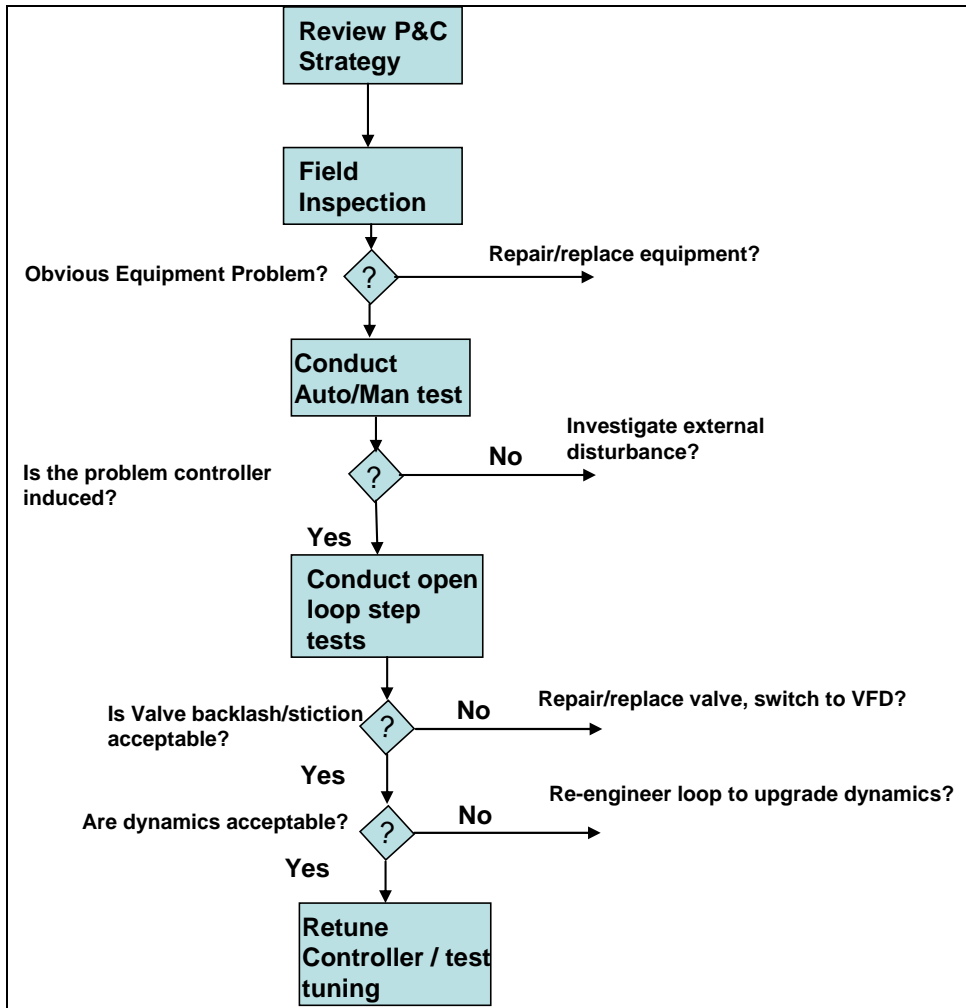

Figure 11 Control Loop Troubleshooting Flowchart

REFERENCES

1. Bialkowski, W.L., Dreams versus reality: A View from Both Sides of the Gap, Pulp and Paper Canada, 94:11, 1993
2. Ettaleb, L., Roche, A., and Dumont, G., Tools for Control Loop Performance Monitoring, Pulp and Paper Research Institute of Canada, January 2003
3. McNabb, C, Progress with Control Performance Monitoring at Boise Paper Solutions Matrikon Users Group Meeting, May 2004
4. Dottori, F., Process Control benefits and the Bottom Line: How I See It!, Pulp and Paper Canada, April 2002